

## 2. BODY

### BODY INFORMATIONS

|                       |      |                       |      |
|-----------------------|------|-----------------------|------|
| Body length ext (mm)  | 4140 | Effective length (mm) | 4060 |
| Body width ext (mm)   | 2540 | Effective width (mm)  | 2460 |
| Body height ext. (mm) | 2110 | Effective height (mm) | 1900 |
| Exemple REGNAULT      | -    |                       |      |

### TECHNICAL DESCRIPTION

#### SUB FRAME

- Metallic sub frame, U sectional steel.
- Fitting on frame in comply per manufacturer specifications. (Bodywork fitting Guide).

#### BASE / FLOOR

- Metallic cross, rectangle tube, in 235 steel, spaced 415mm, welded on the side of chassis auxiliary frame.
- Flank edge, U sectional steel.
- Integration of 4 lashing rings each side, 2500daN capacity.
- Steel sheet floor 4/6.

#### HEADBOARD

- Headboard, steel sheet 30/10 welded on front sub frame, height 1200mm.

#### OPENING

- 2 Drop down sideboards on each side, ribbed steel sheet 30/10, height 600mm, removable with 2 locking gears on each sideboards, above steel frame height 200mm.
- Intermediary and back pillars, height 800mm, removable.
- 1 Rear tailgate identical side boards, height 600mm, drop type and removable with chain (For horizontal position), 2 folding step board on each side, stapes welded on top of the tailgate on each side.

#### TARPAULIN & FRAME

- 3 Frames, metallic, steel tubes, dihedral shape, height 1900mm (center).
- 5 Longitudinal bars between frames, hanging by bolt and pin.
- Polyester tarpaulin 650gr/m<sup>2</sup>, colour to define the command, falling on to the sides, fastened by straps and cover hook.

Drawing :

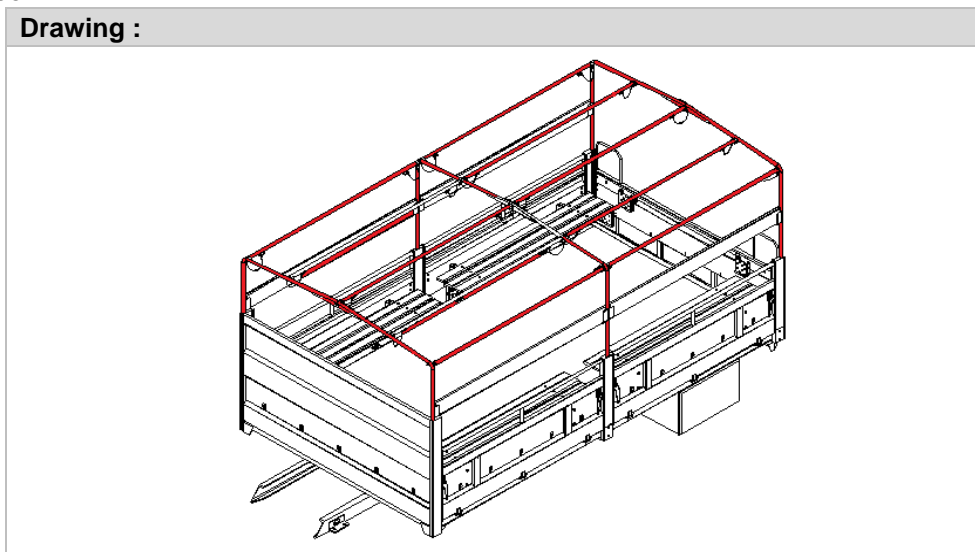

**OTHER EQUIPMENT**

- 4 Rubber buffers on the rear to receive the rear tailgate.
- 1 Tire inflation Gun, with gauge and chuck.
- 1 Spare wheel carrier, compatible pneumatic 395/85 R20, location between the cab and body.

**Drawing :**

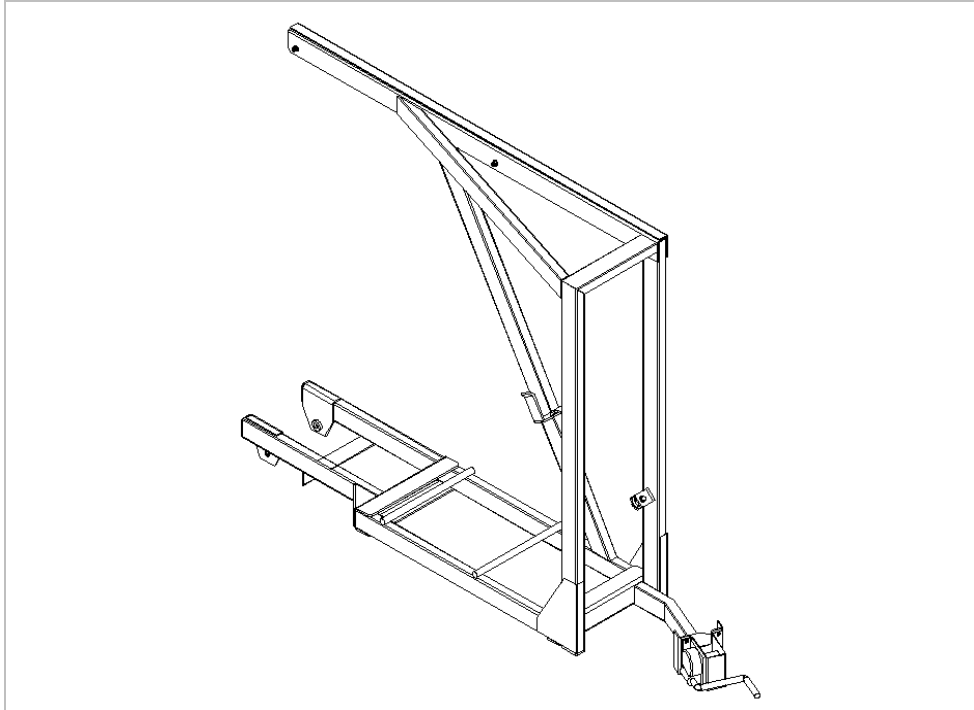

- 1 Steel tool-box, overall dimensions L: 600mm P: 450mm H: 400mm, position in the wheelbase left.
- 1 Steel support for jerry cans, position in the overhang right : 2 jerry cans "Water", capacity jerry cans 20L.
- 1 Steel support for jerry cans, position in the overhang left : 2 jerry cans "Fuel", capacity jerry cans 20L.

**Drawing :**

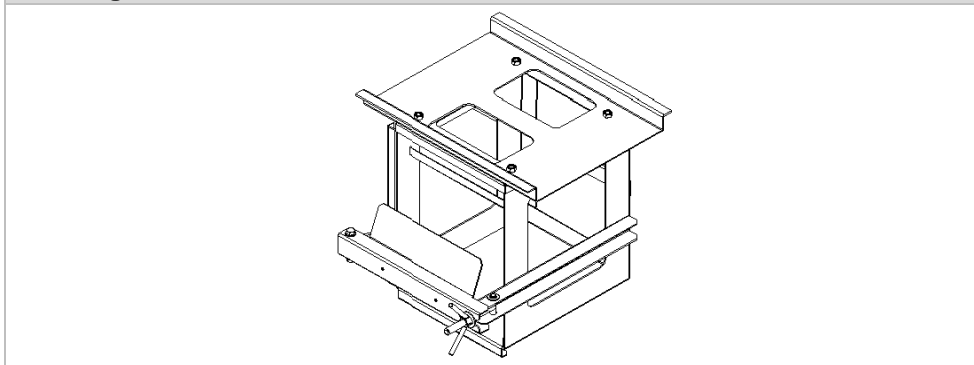

- 2 Foldable wood bench seats on each side, steel frame, for 12 soldiers with equipment, fixed on sideboards, bench seats width 1800mm, seat width per person 600mm.

**Drawing :**

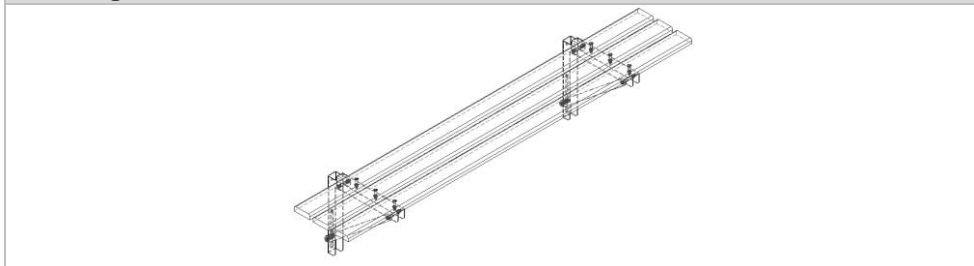

**REGULATORY EQUIPMENT**

- Back wings folded sheet steel, with mud flaps.
- White and red outline marker.
- Without - Side guards fitting regulation.
- Supply and installation of a 2kg fire extinguisher in cabin.
- Without - Lighting and signalling marker lights conforming to the Highway Code.

**SURFACE TREATMENT**

- Cab and chassis remaining in the original colour manufacturer.
- Sandblasting of metallic parts.
- 2 Layers of impressions and 2 layers of polyurethane varnish, colour.

**DOCUMENTATION**

- Certificate of camber.